

# RDH

MINING  EQUIPMENT



## BLOCKHOLE 40D SERIES JUMBO

### Engine

Model Deutz D914L06

### Transmission

Model Dana Powershift 20000 Series

### Operating Specifications

Reaches draw points up to 42' (12.8 m)

Remote control tramming, drilling, loading

# RDH BLOCKHOLE 40D SERIES JUMBO

## TECHNICAL SPECIFICATIONS

High reach and fully remote for draw points up to 40'

### FEATURES

- Diesel hydraulic drilling
- Hydraulic four stage boom
- Fully remote equipped
- Four wheel drive articulated
- Protective canopy
- 3 x 500 watt drilling lights
- Ansul fire suppression

### REMOTE

Bi-directional control safety tilt and emergency stop. Programmable proportional control to throttle, boom rotate, boom up/down and extension by tele-remote drilling and loading

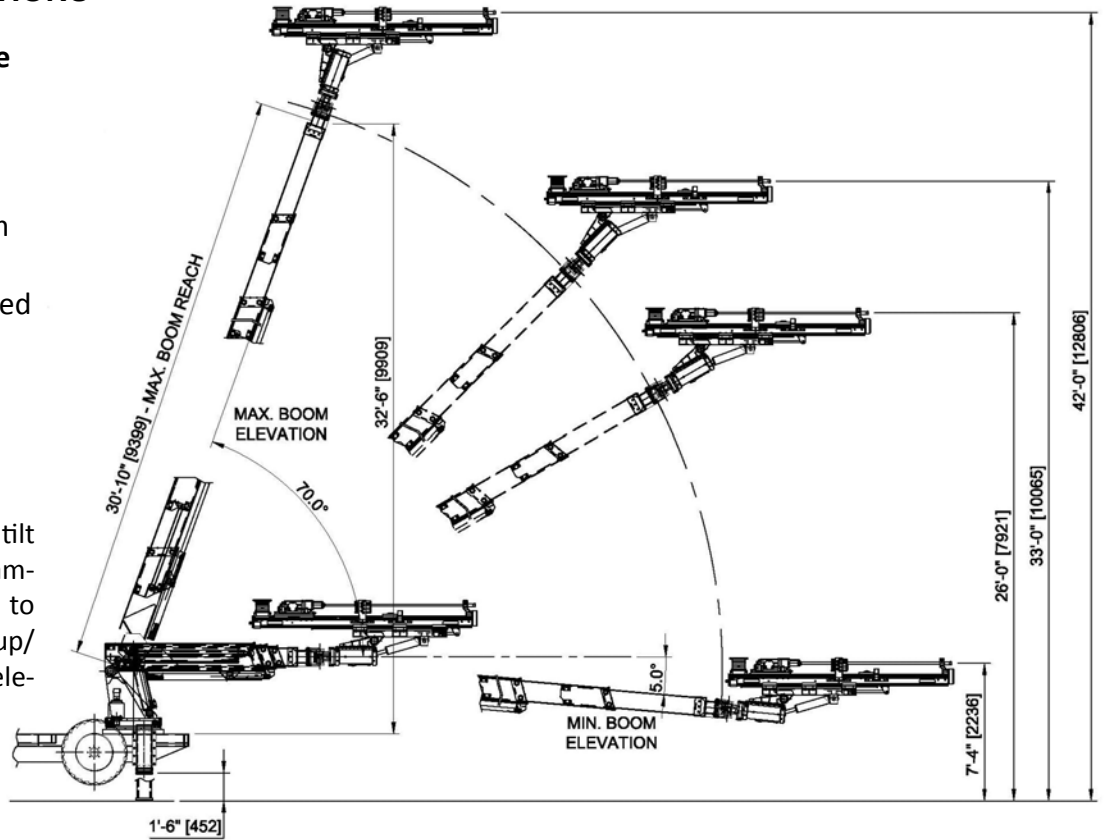

### BOOM 209

Weight	5,000 lbs 2268 kg
Length extended	30'10" 9399 mm
Length retracted	10-11" 3327 mm
Rotation	270°
Altitude	-5 to +70°

### BOOM 109

Weight	4,000 lbs 1814 kg
Length extended	20'10" 6350 mm
Length retracted	10-11" 3327 mm
Rotation	270°
Altitude	-5 to +70°

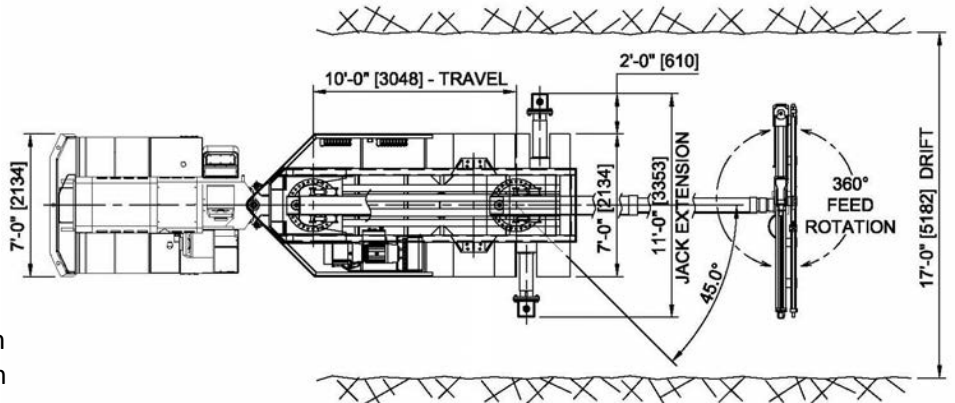

### RDH 600 CARRIER

Engine	Deutz D914L06
Transmission	Dana 20,000
Axles	Dana 113
Brakes	Wet Disc
Electrical	24 Volt
Operating Weight	40000 lbs (18144 kg)

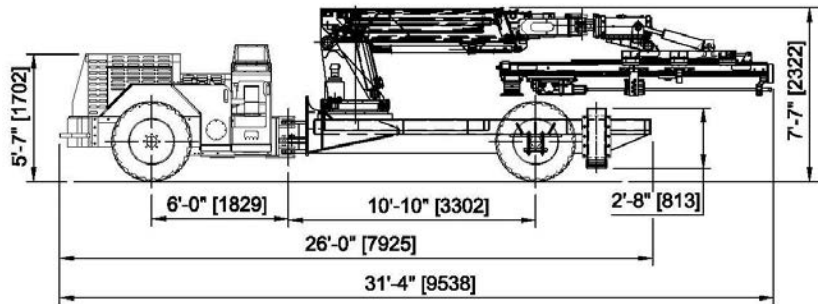

ISO 9001-2008  
REGISTERED

CWB  
CERTIFIED

Manufactured by:  
RDH Mining Equipment  
904 Hwy 64 Alban, Ontario  
Canada P0M 1A0  
Tel: (705) 857-2154 Fax: (705) 857-3285  
Email: sales@rdhminingequipment.com  
Website: www.rdhminingequipment.com