

OUR COMMITMENT
TO CUSTOMER SATISFACTION,
QUALITY, AND SERVICE

At RDH Mining Equipment we are committed to finding innovative and cost-effective ways of increasing equipment productivity while decreasing equipment costs for our customers.

We incorporate the latest technology to ensure the highest standards are met during every step of the manufacturing process.

We stand behind each of our products and continually enhance our product line with exciting innovations that make our equipment invaluable at customer sites around the world.

Our skilled technical staff ensure our drill rigs are engineered to provide the greatest drilling performance to meet the demands of your tight production schedules.

RDH Mining Equipment aims to enhance customer satisfaction through the continual improvement of our processes and is a ISO 9001 registered organization, consistently providing products that meets our customer and applicable statutory and regulatory requirements.



simplifying heavy equipment



904 Hwy 64 Alban, Ontario
Canada P0M 1A0

1.800.401.3588 toll
705.857.2154 ph
705.857.3265 fax

sales@rdhminingequipment.com
www.rdhminingequipment.com

HAULMASTER 600-7LPC

High production, seven ton, conveyor bed, potash haul truck



Dump body capacity up to 6.3 m³ (8.3 yds³)
6.4 metric tonne (14000 lbs) payload
Tramming height 1.7 m
Powerful Deutz D914L06 engine



simplifying heavy equipment

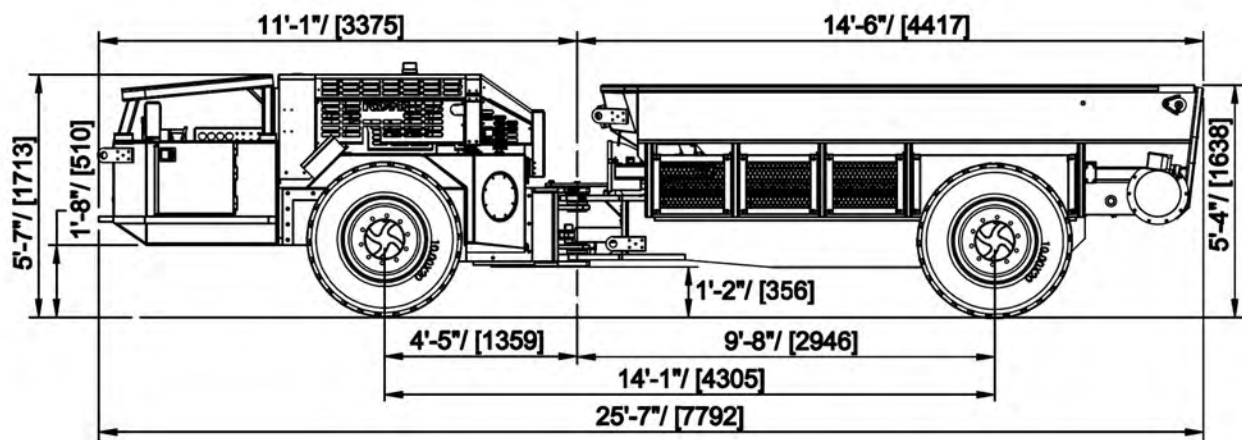

Carrier

Powertrain

Engine: Deutz D914L06 six cylinder, air-cooled, diesel, Tier III, c/w fuel filter & water separator
 Power rating at 2300 rpm.....86.5 kW / 116 hp
 Torque at 1500 rpm.....375 Nm / 276.6 lb-ft
 Exhaust.....catalytic purifier with silencer
 Air intakeDonaldson two-stage
 Four wheel drive
 Transmission.....Dana 20000 series, 3 speed forward / reverse
 Axles.....Dana 113
 Tires13.70 x 18
 Service/emergency/parking brakes.....spring applied hydraulically released
 Remote brake release kit for towing

Electrical

Electrical system24 V
 Batteries2 x 12 VDC
 Trimming/working lights.....4 front, 3 rear, LED 27 W
 Horn and reverse alarm

Other Standard Equipment

Central grease point—manual
 Standard gauges and instrumentation
 Ansul fire suppression system —manual, 20 lbs, four nozzle
 Copy Parts/Operators/Service Manuals

All weights, dimensions, and other data reflect a standard unit unless otherwise stated. RDH reserves the right to change this specification without notice.

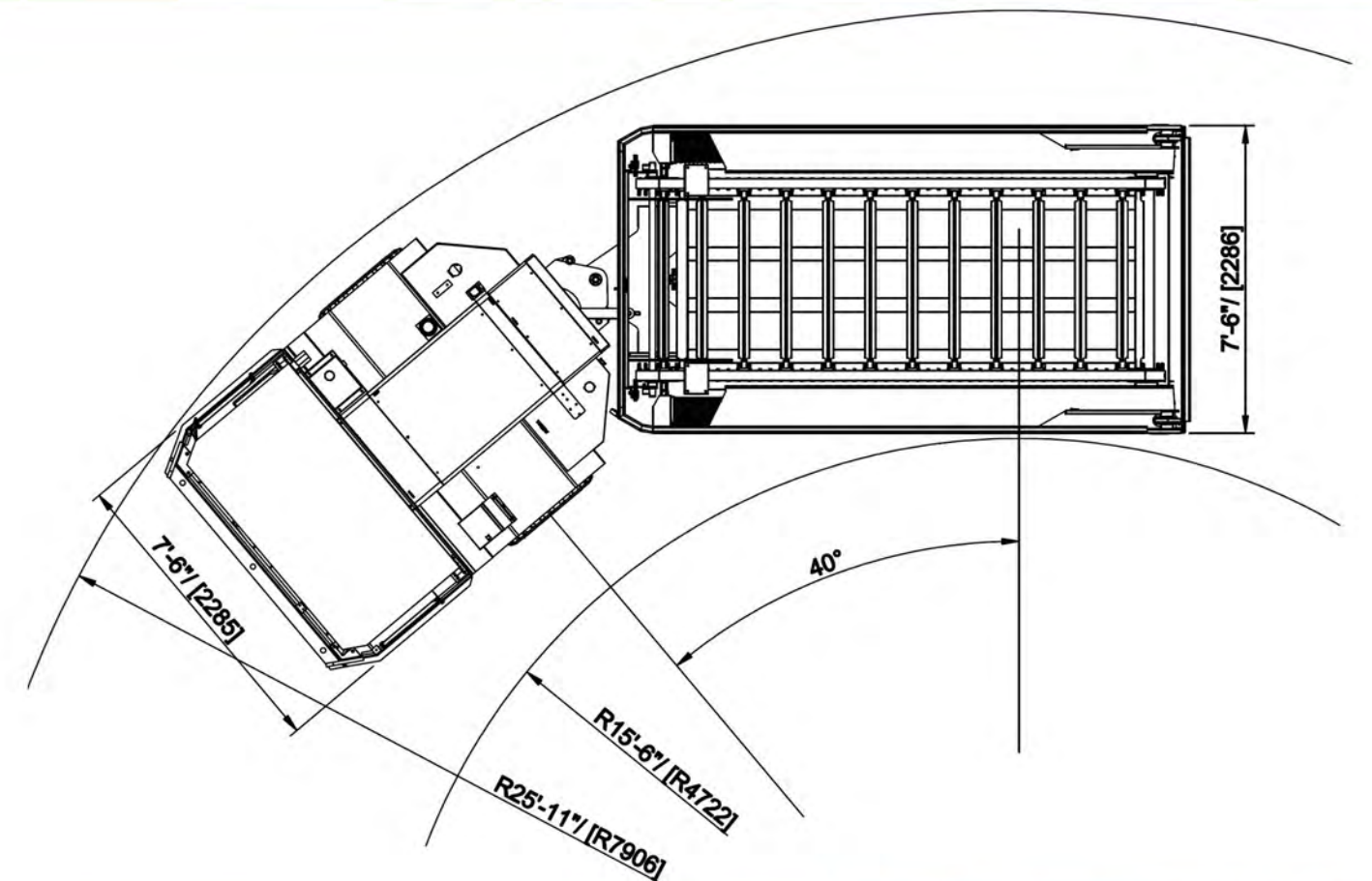

Hydraulic System

Variable displacement load sensing , closed center system with a piston pump
 Hydraulic pilot operated joystick steer control
 Oil level gauge on oil tank, oil filter indicator

Options

Various engine models
 Ejector dump body
 Automatic centralized lubrication system
 Electric oil transfer pump
 ROPS/FOPS approved protective canopy or enclosed cabin
 Reverse camera system
 Remote control system
 ANSUL Checkfire fire suppression system
 Fast fill system
 Fire extinguisher
 Strobe light
 Cold weather package
 Driver door interlock
 Other custom options upon request

WEIGHTS

- Empty vehicle weight: 13562 kg (29900 lbs)
- Payload: 6350 kg (14000 lbs)

DIMENSIONS

- Dump body capacity (heaped): 6.3 m³ (8.3 yds³)
- Width: 2.3 m (90")
- Total length: 7.8 m (307")
- Trimming height: 1.7 m (67")
- Inside turning radius: 4722 mm (186")
- Outside turning radius: 7906 mm (311")
- Steering angle: 40°

All weights, dimensions, and other data reflect a standard unit unless otherwise stated. RDH reserves the right to change this specification without notice.