

**OUR COMMITMENT
TO CUSTOMER SATISFACTION,
QUALITY, AND SERVICE**

At RDH Mining Equipment we are committed to finding innovative and cost-effective ways of increasing equipment productivity while decreasing equipment costs for our customers.

We incorporate the latest technology to ensure the highest standards are met during every step of the manufacturing process.

We stand behind each of our products and continually enhance our product line with exciting innovations that make our equipment invaluable at customer sites around the world.

Our skilled technical staff ensure our drill rigs are engineered to provide the greatest drilling performance to meet the demands of your tight production schedules.

RDH Mining Equipment aims to enhance customer satisfaction through the continual improvement of our processes and is a ISO 9001 registered organization, consistently providing products that meets our customer and applicable statutory and regulatory requirements.



MUCKMASTER 200-250-300

High production, 2 to 3 cubic yard capacity LHD



simplifying heavy equipment



904 Hwy 64 Alban, Ontario
Canada P0M 1A0

1.800.401.3588 toll
705.857.2154 ph
705.857.3265 fax

sales@rdhminingequipment.com
www.rdhminingequipment.com

Bucket capacities between 1.5 m³ to 2.3 m³

Powerful 130 kW (174 hp) engine

Tramming height 2.3 m

Easy access service points



simplifying heavy equipment

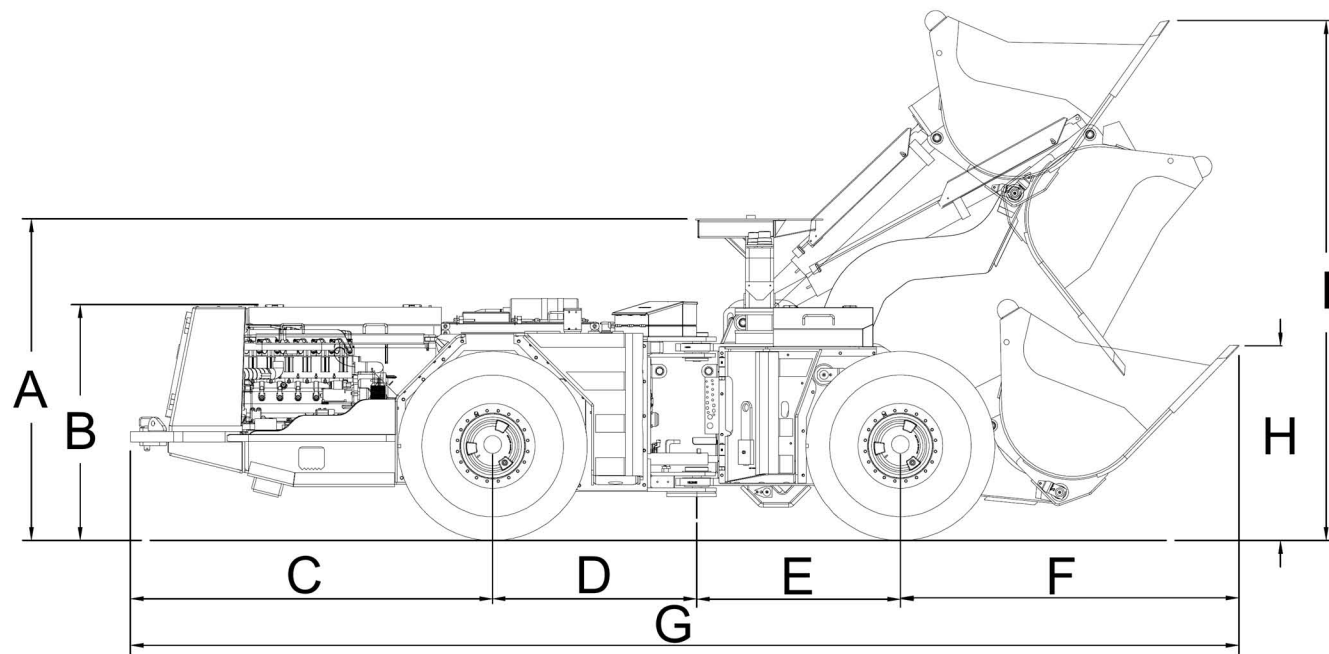

Dimensions

	200		250		300	
	1.5 m ³ 2 yds ³	mm in	1.9 m ³ 2.5 yds ³	mm in	2.3 m ³ 3 yds ³	mm in
A Height at canopy	2271	89	2271	89	2271	89
B Height at engine end	1655	65	1655	65	1655	65
C Rear bumper to centerline of rear axle	2604	103	2604	103	2604	103
D Centerline of rear axle to centerline of midship	1467	48	1467	48	1467	48
E Centerline of midship to centerline of front axle	1463	48	1463	48	1463	48
F Centerline of front axle to tip of bucket	2261	89	2337	92	2433	96
G Overall length	7798	307	7872	310	7969	314
H Height to top of bucket lip—tramming	1207	48	1262	50	1359	54
I Height to top of bucket lip—boom extended	3519	139	3581	141	3696	146
J Overall width	1837	72	1837	72	1854	73
K Outside clearance—turning radius	5425	214	5425	214	5530	218
L Inside clearance—turning radius	3149	124	3149	124	3149	124
M Articulation angle	40°		40°		40°	
N Width—bucket	1613	63	1702	67	1854	73
Tire size	12.00 x 24		12.00 x 24		12.00 x 24	
Tramming capacity	4490 kg / 9899 lbs		4490 kg / 9899 lbs		4490 kg / 9899 lbs	
Breakout force, lift	5790 kg / 12765 lbs		5790 kg / 12765 lbs		5790 kg / 12765 lbs	
Breakout force, tilt	7052 kg / 15547 lbs		7052 kg / 15547 lbs		7052 kg / 15547 lbs	
Tipping load	16900 kg / 37258 lbs		16900 kg / 37258 lbs		16900 kg / 37258 lbs	
Approximate weight of standard equipped unit with canopy (empty bucket)	14470 kg / 31900 lbs		15150 kg / 33400 lbs		15830 kg / 34900 lbs	

All weights, dimensions, and other data reflect a standard unit unless otherwise stated. RDH reserves the right to change this specification without notice.

HYDRAULIC SYSTEM

- Variable displacement load sensing, closed center system with a piston pump
- Hydraulic pilot operated joystick steering control.
- Oil level gauge on oil tank, oil filter indicator

OPTIONAL EQUIPMENT

- Various engine models
- Ejector bucket
- Automatic centralized lubrication system
- Ride control system
- Electric oil filling pump
- ROPS/FOPS approved protective canopy
- ROPS/FOPS approved enclosed cabin
- ANSUL Checkfire fire suppression system
- Fast fill system
- Remote control system
- Reverse camera system
- Fire extinguisher
- Cable reel
- Strobe light
- Quick attach forklift package
- Cold weather package
- Driver door interlock
- Other custom options upon request

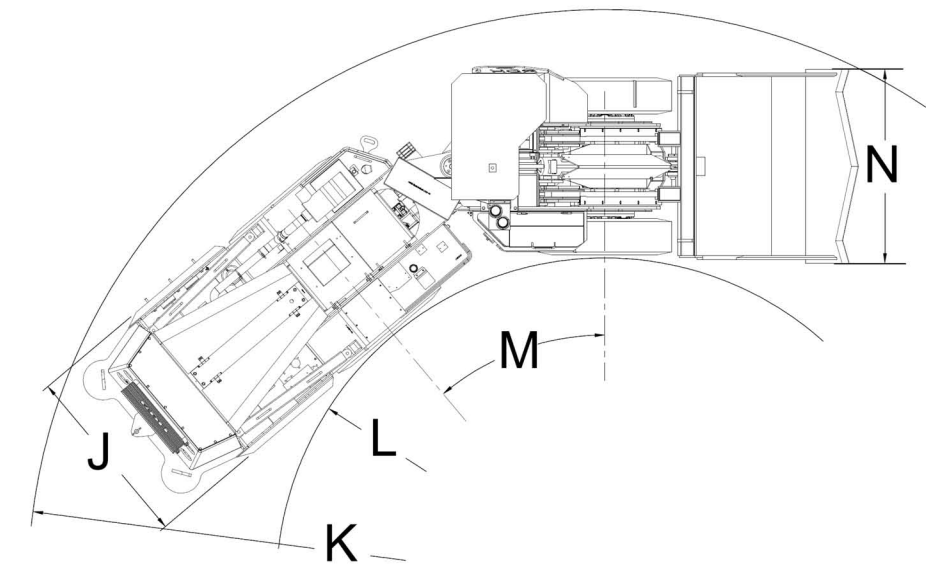

Carrier

Powertrain

Engine: Deutz TCD914L06 six cylinder, turbocharged, air-cooled, diesel, Tier III, c/w fuel filter & water separator
 Power rating at 2300 rpm.....130 kW / 174 hp
 Torque at 1500 rpm.....650 Nm / 479 lb-ft
 Exhaust.....catalytic purifier with silencer
 Air intakeDonaldson two-stage
 Four wheel drive
 Transmission.....Dana 32000 series, 4 speed forward / reverse
 Converter.....Dana C270
 Axles.....Dana 37R
 Service/emergency/parking brakes.....spring applied hydraulically released
 Remote brake release kit for towing

Electrical

Electrical system24 V
 Batteries2 x 12 VDC
 Tramming/working lights.....4 front, 2 rear, LED 27 W
 Horn and reverse alarm

Other Standard Equipment

Central grease point—manual
 Standard gauges and instrumentation
 Ansul fire suppression system — manual, 20 lbs, four nozzle
 Copy Parts/Operators/Service Manuals

All weights, dimensions, and other data reflect a standard unit unless otherwise stated. RDH reserves the right to change this specification without notice.